

# • SPECIFICATION •

## • 3412 - Hoxton Single Lever Basin Mixer

- Manufactured in the UK
- Suitable for both high & low pressures
- Flow straightener supplied
- Plug lifter for a pop-up waste
- Easy to operate single hand design

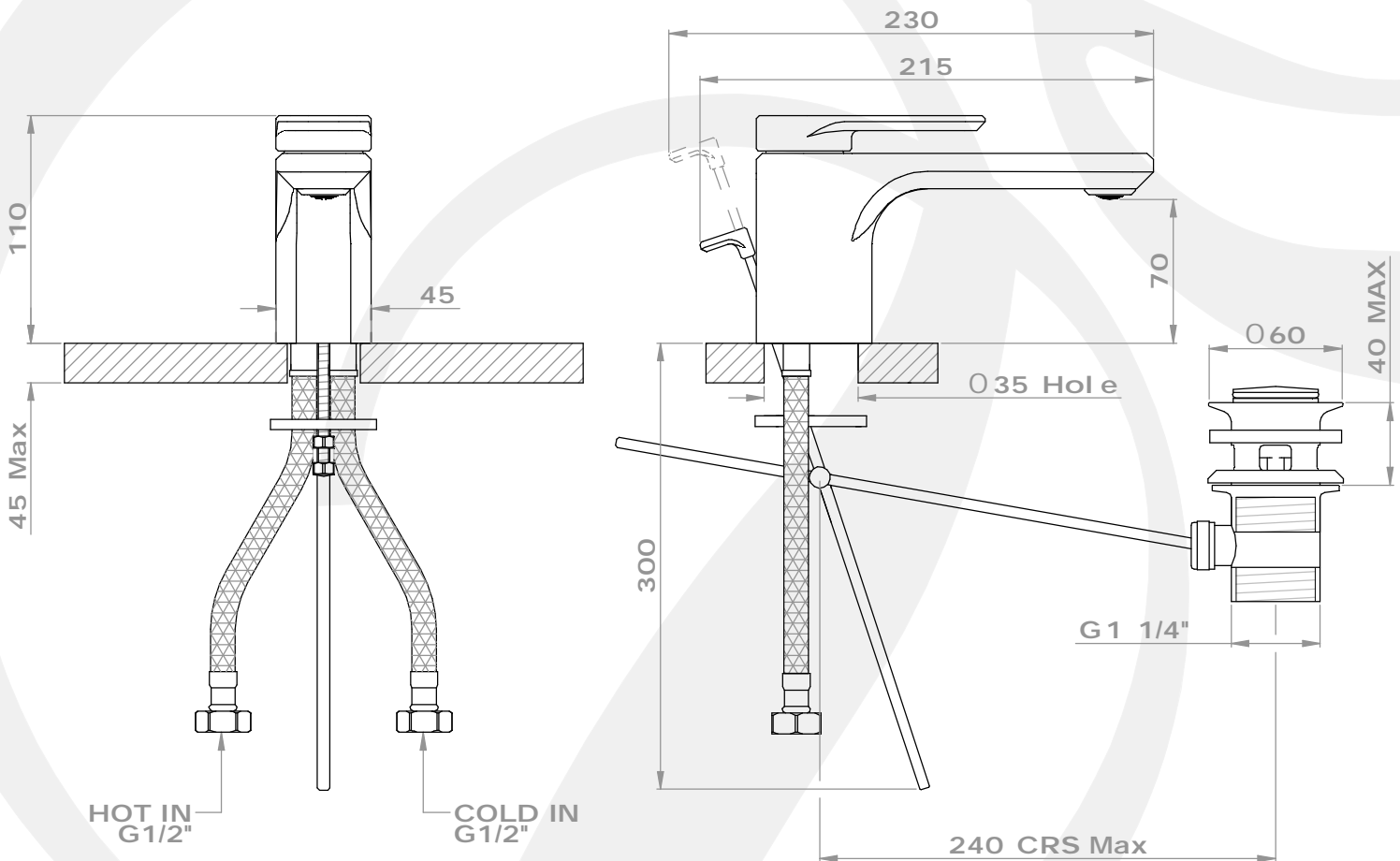
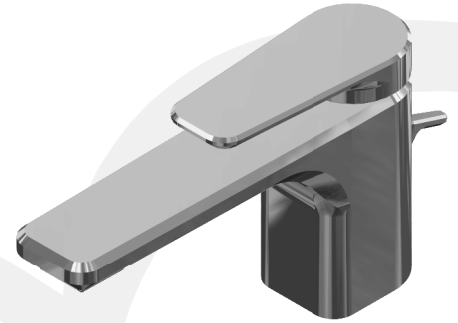

### Available Finishes:

- Chrome
- Nickel
- Pewter

- Temp Range:  
Min 1°C / 34°F  
Max 70°C / 158°F

- Recommended Supply Pressure:  
Min 1bar / 15psi  
Max 5bar / 75psi

- Packed Weight:  
3kg

### Available Options:

- Flow regulated spout (Prefix AR.)

ALL UNITS IN mm  
UNLESS OTHERWISE  
STATED