

• SPECIFICATION •

• 4387 - MINOAN MONOBLOC SINK MIXER WITH PORCELAIN LEVER HANDLES

- Handcrafted in the UK
- 1/4 turn ceramic disc flow control
- Vernier insert for accurate handle alignment
- Unique handle construction with integral bearing ring
- Supplied with white ceramic levers
- Flexible connectors for easier installation
- Bi-flow spout for unequal supply pressures

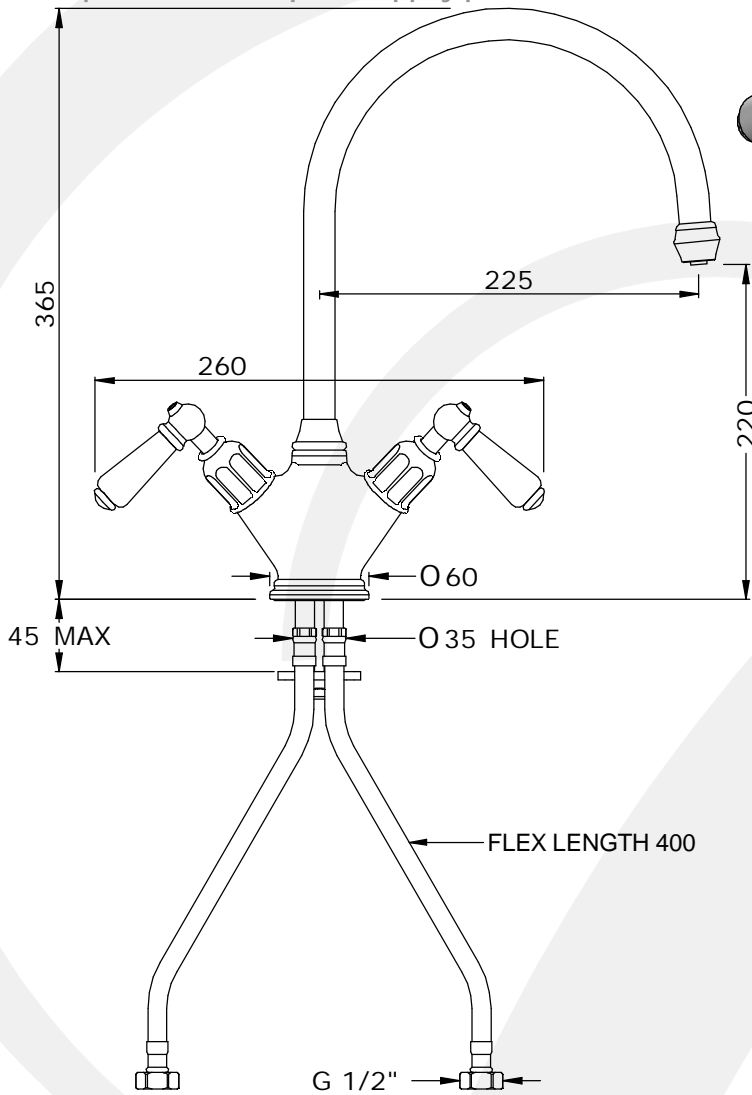

ALL UNITS IN mm
UNLESS OTHERWISE
STATED

Available Finishes:

- Chrome
- Nickel
- Pewter
- Polished Brass
- Satin Brass
- Aged Brass
- Gold
- English Bronze

• Temp Range:
Min 1°C / 34°F
Max 70°C / 158°F

• Recommended
Working Pressure:
Min 0.5bar / 7.5psi
Max 5bar / 75psi

• Packed Weight:
3.31kg

Available Options:

- Aerated single flow spout (Prefix A.)
- 5.7L/min regulated spout (Prefix AR.)
- Black ceramic or plated levers
- Corian and Avonite Lever Finishes
- Rinse version
- Matching soap dispensers

Flow Rates:

- 1 Bar: 12.0 L/Min
- 2 Bar: 18.8 L/Min
- 3 Bar: 20.4 L/Min