

• SPECIFICATION •

• 3435 - HOXTON BASIN 3 HOLE DECK MOUNTED MIXER

- HANDCRAFTED IN THE UK
- CERAMIC DISC FLOW CONTROL
- VERNIER INSERT FOR ACCURATE HANDLE ALIGNMENT
- UNIQUE HANDLE CONSTRUCTION WITH INTEGRAL BEARING RING
- FLEXIBLE CONNECTORS FOR EASIER INSTALLATION
- SUPPLIED WITH POP UP WASTE
- SOLID BRASS CONSTRUCTION

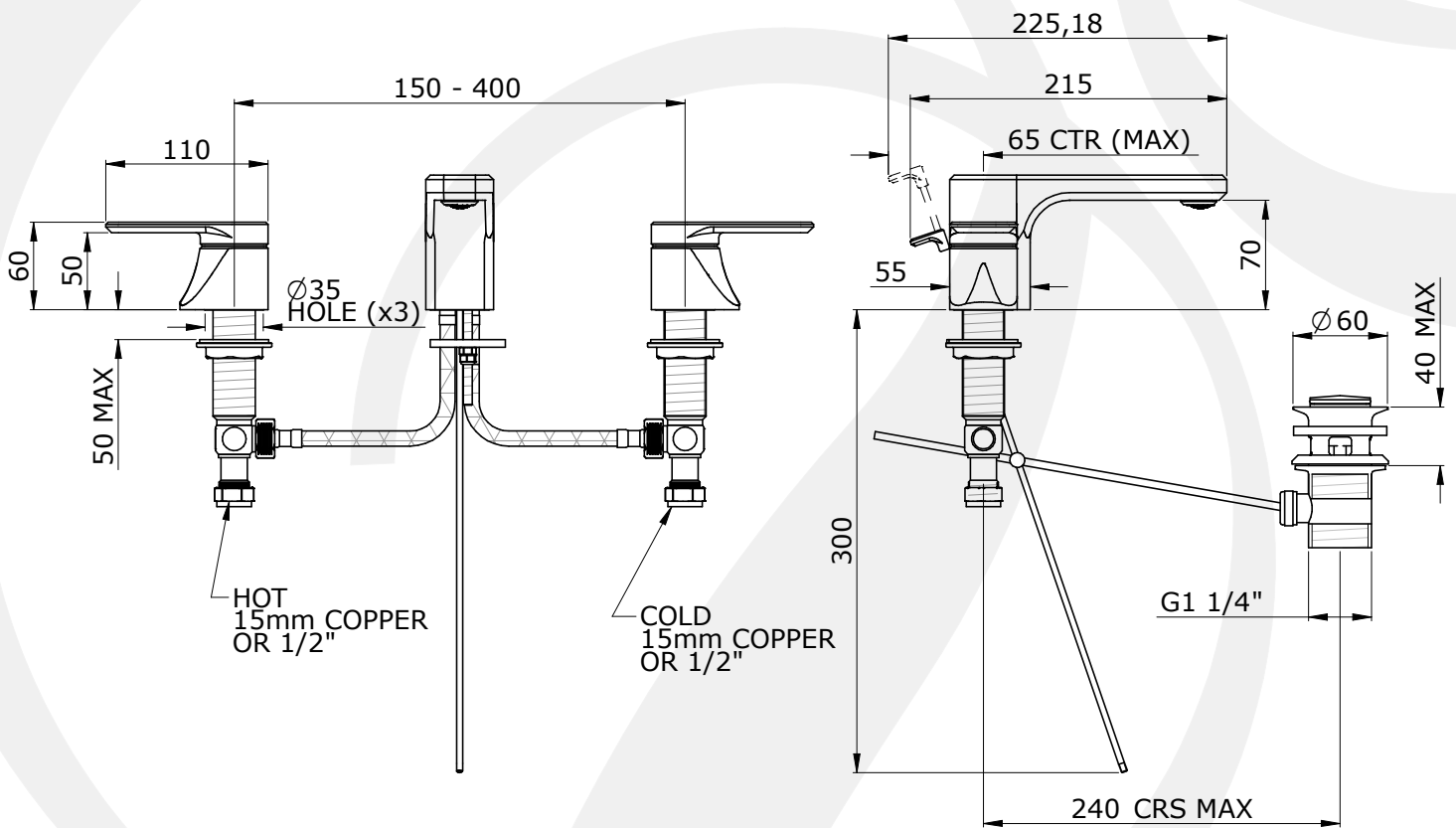
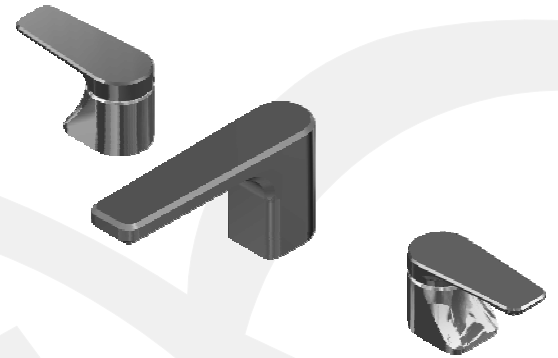

AVAILABLE FINISHES:

- CHROME
- NICKEL
- PEWTER
- POLISHED BRASS
- SATIN BRASS
- GOLD
- ENGLISH BRONZE

• TEMP RANGE:
MIN 1°C / 34°F
MAX 70°C / 158°F

• RECOMMENDED
SUPPLY PRESSURE:
MIN 0.5BAR / 7PSI
MAX 5BAR / 75PSI

• PACKED WEIGHT:
#KG

AVAILABLE OPTIONS:

- 5.0 L/MIN REGULATED SPOUT (PREFIX AR.)

FLOW RATES:

- 1 BAR: L/MIN
- 2 BAR: L/MIN
- 3 BAR: L/MIN