

PROGRAMMA MISCELAZIONE BAGNO  
BATH MIXING PROGRAM  
PROGRAMME DU MITIGEUR POUR LA SALLE DE BAIN  
BAD-MISCHUNGSPROGRAMM  
PROGRAMA MEZCLADORES BAÑO  
ПРОГРАММА СМЕСИТЕЛЕЙ ДЛЯ ВАННОЙ  
ΑΝΑΜΙΚΤΙΚΟ ΠΡΟΓΡΑΜΜΑ ΜΠΑΝΙΟΥ  
浴室混水产品

# ARCHITECTURAL WELLNESS

*Art. 61011*

*Art. 61013*

*Art. 61015*

*Art. 61017*

*Art. 61019*

*Art. 61020*

*Art. 61041*

**GESSI** 

**Gessi SpA** - Parco Gessi

13037 Serravalle Sesia (Vercelli) - Italy

Phone +39 0163 454111 - Facsimile +39 0163 459273

[www.gessi.com](http://www.gessi.com) - [gessi@gessi.it](mailto:gessi@gessi.it)



## Art. 61011

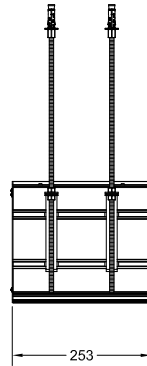
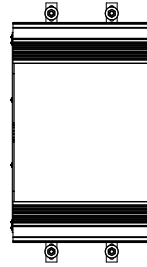
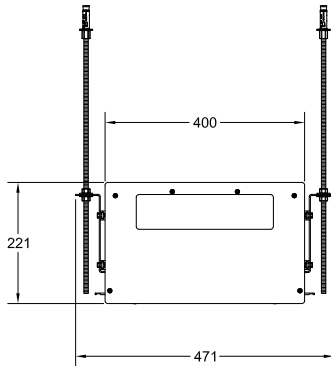

## Art. 61013

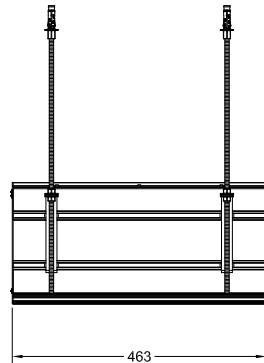
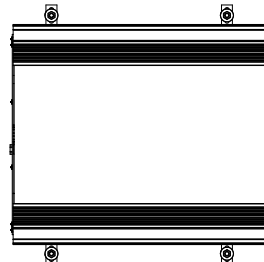
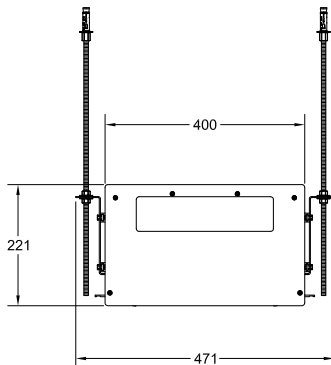



## Art. 61015

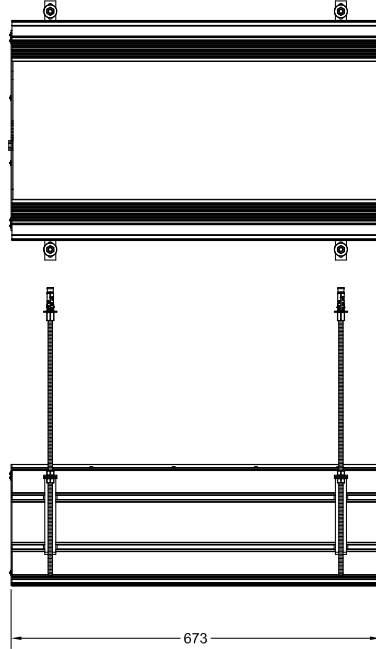
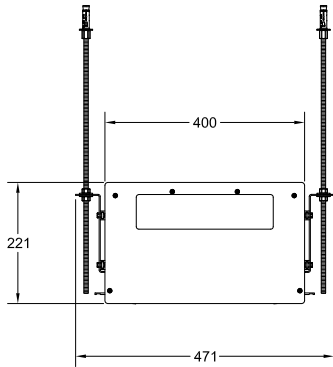

## Art. 61017

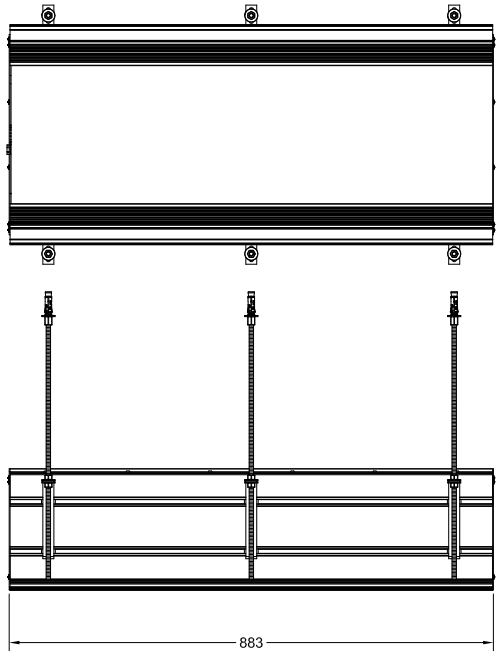
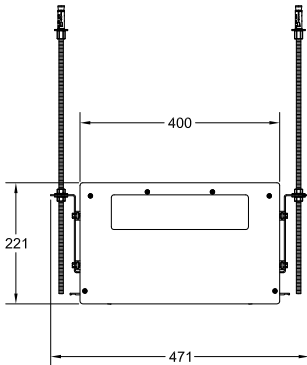



## Art. 61019

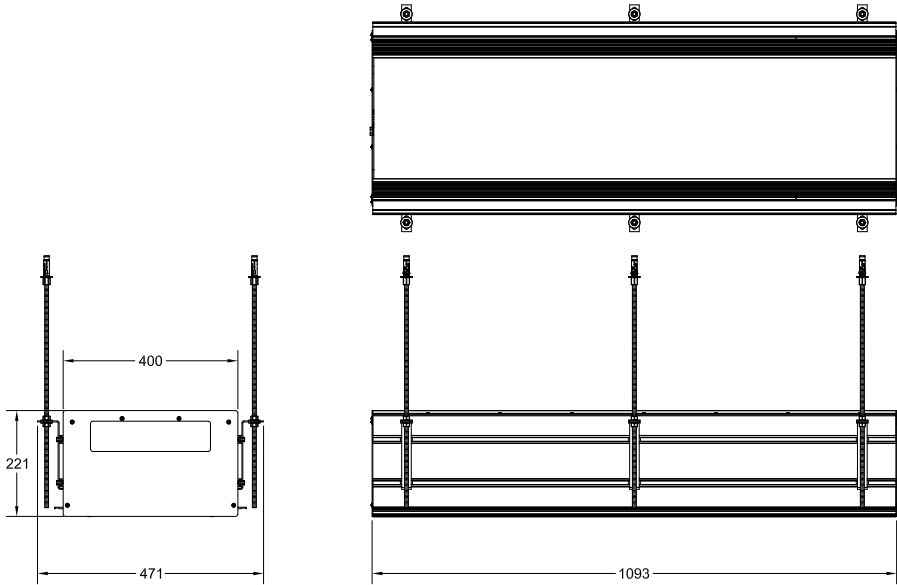

## Art. 61020

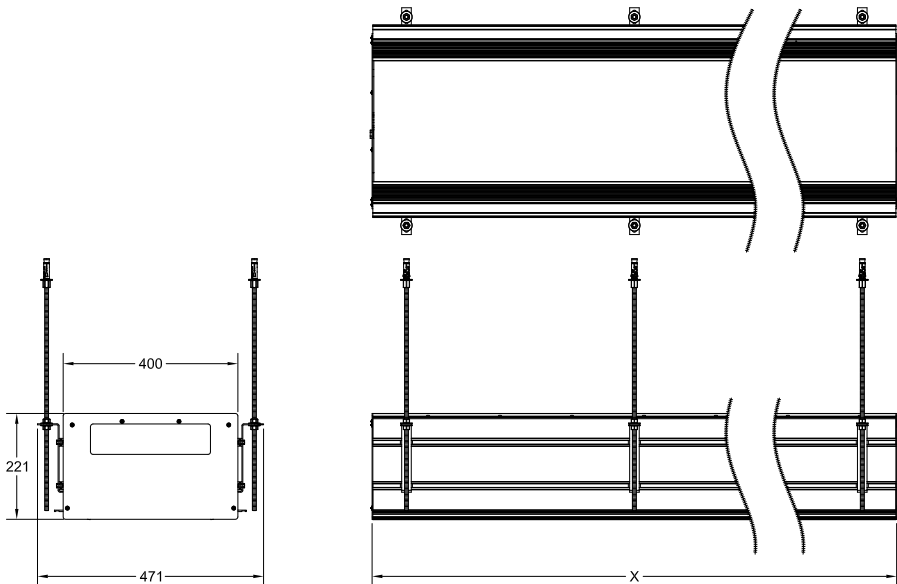



## Art. 61041

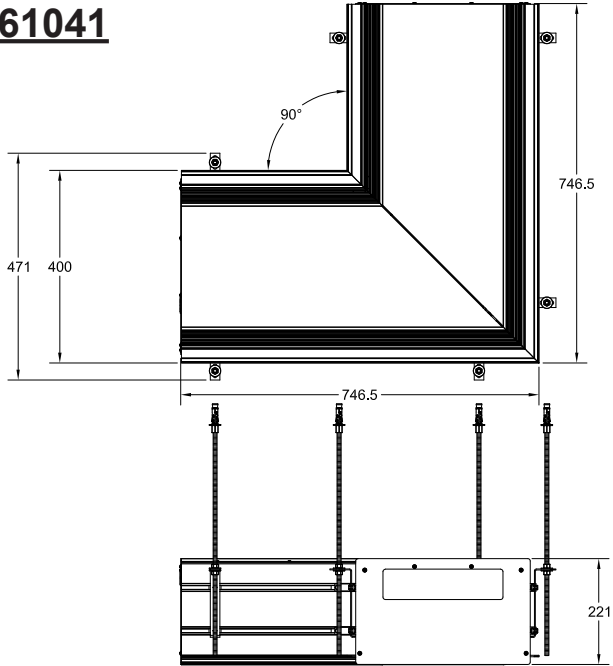



### **Specifiche generali**

- Pesi:

<b>ARTICOLO</b>	<b>PESO (Kg)</b>	<b>PESO CON MODULI (Kg)</b>
61011	~ 5,5	~ 8,5
61013	~ 9,5	~ 15,5
61015	~ 14,5	~ 23,5
61017	~ 17,5	~ 29,5
61019	~ 21,5	~ 36,5
61020	in funzione della lunghezza ~20 Kg/m	in funzione della lunghezza ~ 35 Kg/m
61041	~ 22	~ 37

### **General specification**

- Weight:

<b>ARTICLE</b>	<b>WEIGHT (Kg)</b>	<b>WEIGHT WITH MODULES (Kg)</b>
61011	~ 5,5	~ 8,5
61013	~ 9,5	~ 15,5
61015	~ 14,5	~ 23,5
61017	~ 17,5	~ 29,5
61019	~ 21,5	~ 36,5
61020	according to length ~20 Kg/m	according to length ~ 35 Kg/m
61041	~ 22	~ 37

### **Spécifications générales**

- Poids:

<b>ARTICLE</b>	<b>POIDS (Kg)</b>	<b>POIDS AVEC MODULES (Kg)</b>
61011	~ 5,5	~ 8,5
61013	~ 9,5	~ 15,5
61015	~ 14,5	~ 23,5
61017	~ 17,5	~ 29,5
61019	~ 21,5	~ 36,5
61020	En fonction de la longueur ~20 Kg/m	En fonction de la longueur ~ 35 Kg/m
61041	~ 22	~ 37



### Allgemeine Spezifikationen

- Gewichte:

ARTIKEL	GEWICHT (Kg)	GEWICHT MIT MODULEN (Kg)
61011	~ 5,5	~ 8,5
61013	~ 9,5	~ 15,5
61015	~ 14,5	~ 23,5
61017	~ 17,5	~ 29,5
61019	~ 21,5	~ 36,5
61020	in Abhängigkeit der Länge ~20 Kg/m	in Abhängigkeit der Länge ~ 35 Kg/m
61041	~ 22	~ 37

### Especificación general

- Peso:

ARTÍCULO	PESO (Kg)	PESO CON MÓDULOS (Kg)
61011	~ 5,5	~ 8,5
61013	~ 9,5	~ 15,5
61015	~ 14,5	~ 23,5
61017	~ 17,5	~ 29,5
61019	~ 21,5	~ 36,5
61020	según el largo ~20 Kg/m	según el largo ~ 35 Kg/m
61041	~ 22	~ 37

### Основные характеристики

- Вес:

Артикул	Вес (кг)	Вес с модулями (кг)
61011	~ 5,5	~ 8,5
61013	~ 9,5	~ 15,5
61015	~ 14,5	~ 23,5
61017	~ 17,5	~ 29,5
61019	~ 21,5	~ 36,5
61020	зависимо от длины ~20 кг/м	зависимо от длины ~35 кг/м
61041	~ 22	~ 37



### Γενικές προδιαγραφές

- Βάρη:

ΟΔΗΓΟΣ	ΒΑΡΟΣ (Kg)	ΒΑΡΟΣ ΜΕ ΣΤΟΙΧΕΙΑ (Kg)
61011	~ 5,5	~ 8,5
61013	~ 9,5	~ 15,5
61015	~ 14,5	~ 23,5
61017	~ 17,5	~ 29,5
61019	~ 21,5	~ 36,5
61020	σε συνάρτηση με το μήκος ~20 Kg/m	σε συνάρτηση με το μήκος ~ 35 Kg/m
61041	~ 22	~ 37

### 通用规格

- 重量:

货号	重量 (Kg)	含模块重量 (Kg)
61011	~ 5,5	~ 8,5
61013	~ 9,5	~ 15,5
61015	~ 14,5	~ 23,5
61017	~ 17,5	~ 29,5
61019	~ 21,5	~ 36,5
61020	因长度不同而异 ~20 Kg/m	因长度不同而异 ~35 Kg/m
61041	~ 22	~ 37



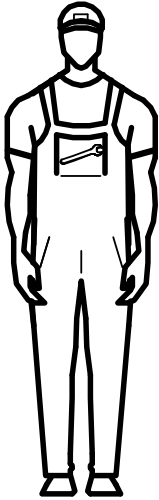

2

Operai necessari per l'installazione  
Workers necessary for the installation

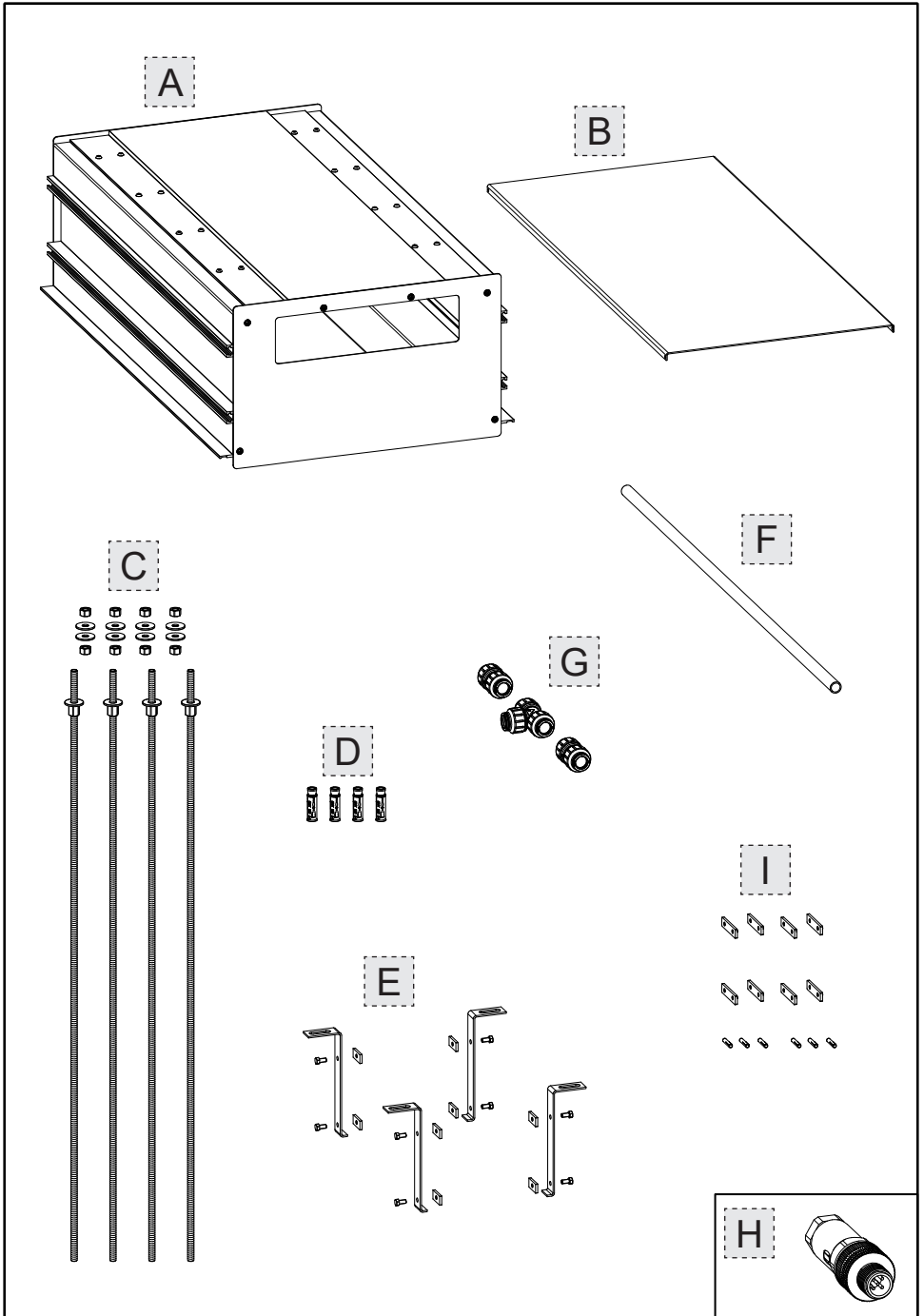



**Contenuto della confezione:**

- A - Binario
- B - Fondo di copertura
- C - Kit di ancoraggio a soffitto
- D - Tasselli di fissaggio
- E - Staffe di fissaggio
- F - Tubi idraulici
- G - Giunti per tubi idraulici
- H - Raccordo per collegamenti elettrici
- I - Kit per collegamento tra binari

**Package content:**

- A - Track
- B - Covering bottom
- C - Kit for ceiling fastening
- D - Fastening plugs
- E - Fixing brackets
- F - Hydraulic pipes
- G - Joints for hydraulic pipes
- H - Union for electrical connections
- I - Connection kit between tracks

**Contenu de l'emballage:**

- A - Guidage
- B - Fond de couverture
- C - Kit d'ancrage au plafond
- D - Fiches de fixation
- E - Étriers de fixation
- F - Tuyaux hydrauliques
- G - Joints pour les tuyaux hydrauliques
- H - Raccordement pour connexions électriques
- I - Kit pour la connexion entre les rails

**Inhalt der Verpackung:**

- A - Schiene
- B - Untergrund der Abdeckung
- C - Bausatz für Deckenverankerung
- D - Befestigungsdübel
- E - Befestigungsbügel
- F - Hydraulische Rohrleitungen
- G - Kupplungen für hydraulische Rohrleitungen
- H - Verbindungsstück für die elektrischen Anschlüsse
- I - Bausatz für den Anschluss zwischen den Schienen

**Contenido de la caja:**

- A - Binario
- B - Fondo de cobertura
- C - Juego de fijación en el techo
- D - Tacos de fijación
- E - Bridas de fijación
- F - Tubos hidráulicos
- G - Juntas para tubos hidráulicos
- H - Unión para conexiones eléctricas
- I - Juego para conexión entre binarios

**Содержимое упаковки:**

- A - Рельс
- B - Покрывающее дно
- C - Набор для закрепления в потолке
- D - Крепежные дюбели
- E - Крепежные скобы
- F - Гидравлические трубы
- G - Переходники для гидравлических труб
- H - Штуцер для электрических соединений
- I - Набор для соединения между рельсов

**Περιεχόμενο συσκευασίας:**

- A - Ράγα
- B - Κάτω κάλυμμα
- C - Kit αγκίστρωσης στην οροφή
- D - Τάκοι στερέωσης
- E - Βάσεις στερέωσης
- F - Υδραυλικοί σωλήνες
- G - Σύνδεσμοι υδραυλικών σωλήνων
- H - Ρακόρ ηλεκτρικών συνδέσεων
- I - Kit σύνδεσης ανάμεσα σε ράγες

**包裝內容:**

- A - 安裝軌道
- B - 底蓋
- C - 天花固定套件
- D - 固定楔
- E - 固定架
- F - 水管
- G - 水管管接
- H - 連接器
- I - 軌道連接套件

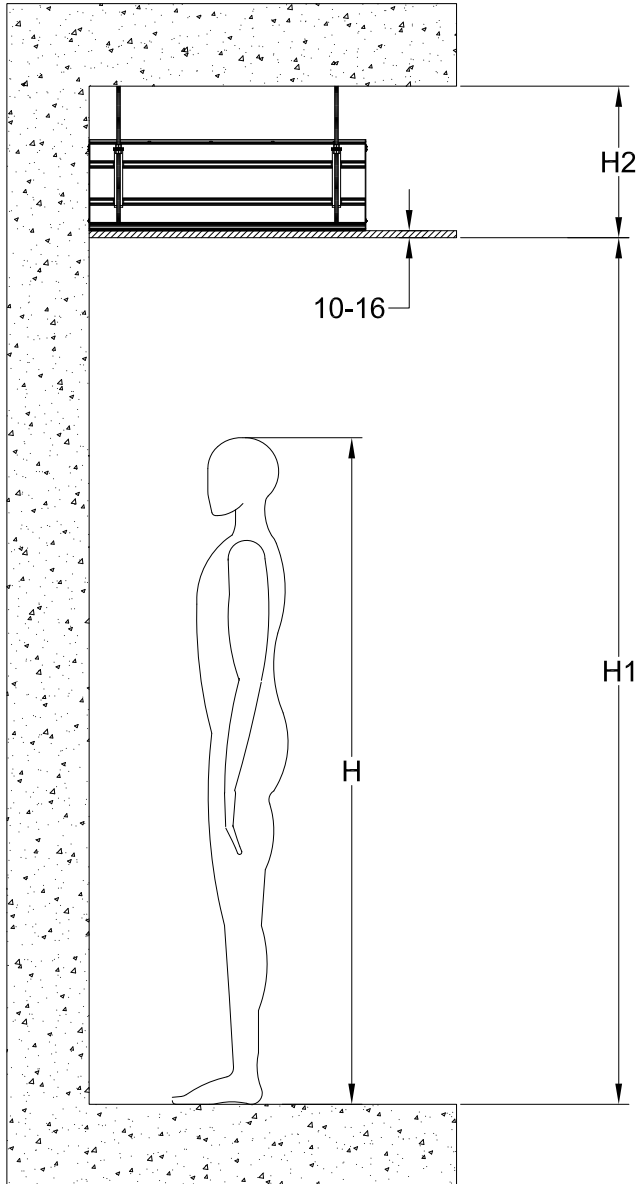



H [mm]	H1 [mm]	H2 [mm]
1600	2100 ÷ 2200	226 MIN
1700	2100 ÷ 2300	
1800	2200 ÷ 2350	935 MAX
1900	2200 ÷ 2400	

**H** = Statura cliente - Customer height - Hauteur client - Größe des Kunden - Altura cliente - Рост клиента  
- Μέγεθος πελάτη - 用户身高

**H1\*\*\*** = Altezza consigliata - Recommended height - Hauteur conseillée - Empfohlene Höhe - Altura aconsejada - Рекомендованная высота - Συνιστώμενο ύψος - 建议高度

**H2** = Distanza di installazione dal soffitto - Distance of installation from the ceiling - Distance d'installation du plafond - Abstand für die Installation auf der Decke - Distancia de instalación del techo - Установочное расстояние от потолка - Απόσταση τοποθέτησης από την οροφή - 安装后与天花板的距离

\*\*\*

*Da valutare considerando le norme in vigore nel paese di installazione*

*To be evaluated according to the rules in force in the installation country*

*À évaluer selon les normes en vigueur dans le pays d'installation*

*Evaluar teniendo en cuenta las normas vigentes en el país de instalación*

*Подвергается оценке, в соответствии с нормами, действующими в стране установки*

*Unter Berücksichtigung der, im Installationsland geltenden Normen abzuwägen*

*Να εκτιμηθεί λαμβάνοντας υπόψη τους κανονισμούς που ισχύουν στην χώρα εγκατάστασης*

*评估中也应该考虑安装所在国现行法律*



**ATTENZIONE:** l'installazione a seguire si basa su un'unica tipologia di struttura essendo la medesima anche per tutte le altre.

**WARNING:** the following installation is based on a unique structure typology, as it is the same also for the others.

**ATTENTION:** l'installation qui doit être effectuée est basée sur un seul type de structure qui est identique pour toutes les autres.

**ACHTUNG:** die nachfolgende Installation basiert auf einer einzigen Strukturtypologie, die auch für alle anderen gleich ist.

**CUIDADO:** la instalación a continuación se basa en una única tipología de estructura ya que es la misma incluso para las demás.

**ВНИМАНИЕ:** следующая установка основывается на одинаковой типологии структуры ввиду того, что она аналогична всем остальным.

**ΠΡΟΣΟΧΗ:** η ακόλουθη εγκατάσταση βασίζεται σε μία ενιαία τυπολογία κατασκευής καθώς αυτή είναι ίδια για όλα τα προϊόντα.

**注意:** 下面基于一种结构型式来进行的安装说明同样适用于其他结构型式。



Fig. 1

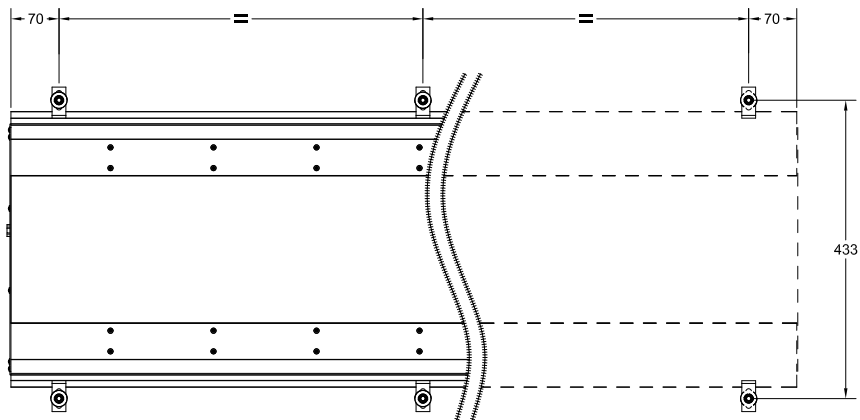

Fig. 2

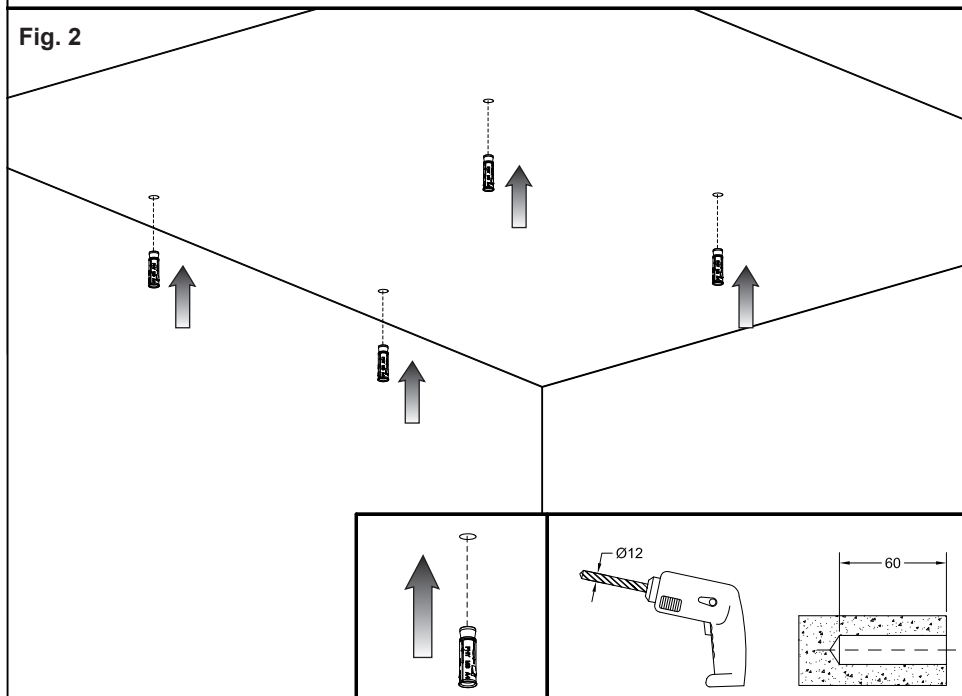



Fig. 3

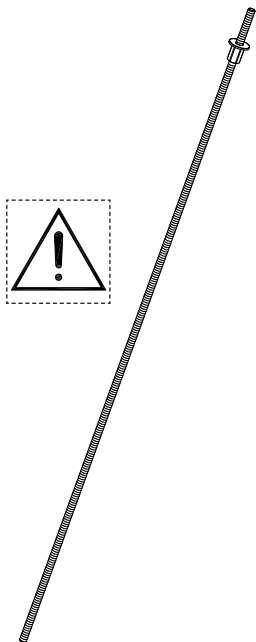

Fig. 4

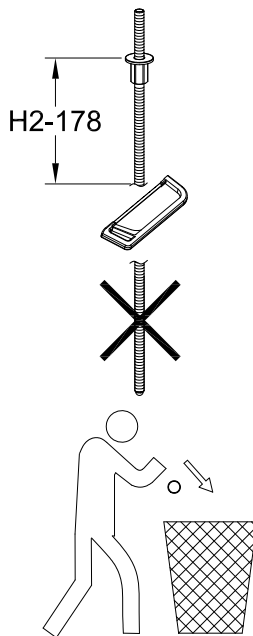
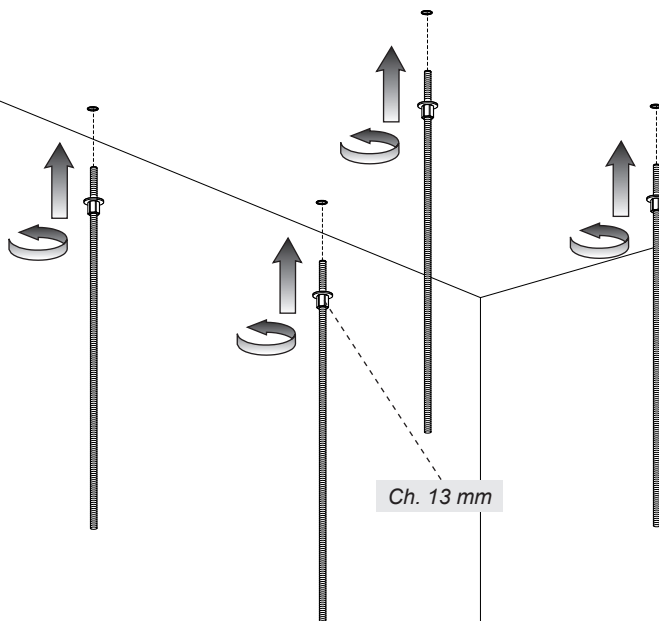

Fig. 5







**ATTENZIONE:** la dotazione di serie comprende un set di fissaggio a soffitto per carichi pesanti, dimensionato per solai in calcestruzzo e/o solai prefabbricati cavi (ancorante in acciaio FISCHER FHY M8 A4). In caso di installazione su altri tipi di solai (ad es. legno) il corretto fissaggio dovrà essere stabilito da un ingegnere calcolatore.

**WARNING:** the standard supply includes a ceiling fastening set for heavy loads, dimensioned for concrete floors and/or hollow prefab floors (steel anchoring device FISCHER FHY M8 A4). In case of installation on other kinds of floors (for ex. wood) the proper fastening should be set by a calculating engineer.

**ATTENTION:** l'équipement de série comprend un jeu de fixation au plafond pour charges lourdes, dimensionné pour plancher en béton et/ou plancher préfabriqués creux (dispositif d'ancrage en acier FISCHER FHY M8 A4). En cas d'installation sur d'autres genres de planchers (par ex. bois) la fixation correcte devra être établie par un ingénieur calculateur.

**ACHTUNG:** Die Lieferung enthält normalerweise einen Befestigungsbausatz für Decken mit schweren Belastungen, der für Betondecken und/oder fabrikfertige Hohldecken dimensioniert wird (Verankerungselement aus Stahl Typ FISCHER FHY M8 A4). Bei der Installation auf sonstigen Typen von Decken (z.B. Holzdecken) soll ein Rechneringenieur sicherstellen, dass die Befestigung ordnungsgemäß erfolgt.

**CUIDADO:** el suministro de serie comprende un juego de fijación para las cargas pesadas, dimensionado en relación a los forjados de hormigón y/o forjados prefabricados huecos (dispositivo de anclaje en acero FISCHER FHY M8 A4). En caso de instalación en otro tipos de forjado (por ejemplo de madera) la fijación correcta tendrá que ser establecida por un ingeniero.

**ВНИМАНИЕ:** серийная оснастка включает в себя комплект для крепления к потолку для больших нагрузок, предназначенный для бетонных перекрытий и/или полых перекрытий-полуфабрикатов (стальной дюбель FISCHER FHY M8 A4). В случае установки на потолки другого типа (напр., деревянные), правильный способ крепления должен определить инженер-расчетчик.

**ΠΡΟΣΟΧΗ:** ο εξοπλισμός σειράς περιλαμβάνει ένα σετ στερέωσης στην οροφή για βαριά φορτία, διαστασιοποιημένο για πατάρια από σκυρόδεμα και/ή προκατασκευασμένα άδεια πατάρια (αγκύριο από χάλυβα FISCHER FHY M8 A4). Σε περίπτωση τοποθέτησης σε άλλους τύπους παταριού (π.χ. ξύλο) η σωστή στερέωση θα πρέπει να καθοριστεί από έναν μηχανικό για τον υπολογισμό.

**注意:** 通用配件中有一套天花板固定重物用套件，适用于混凝土楼板及钢梁预制楼板（采用FISCHER FHY M8 A4钢梁拴紧）。若安装于其他类型的楼板（如木楼板），需由专业工程师设计确定本产品的合适的固定方式。



Fig. 6

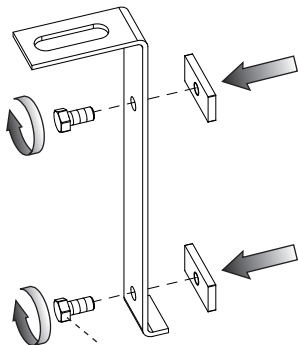
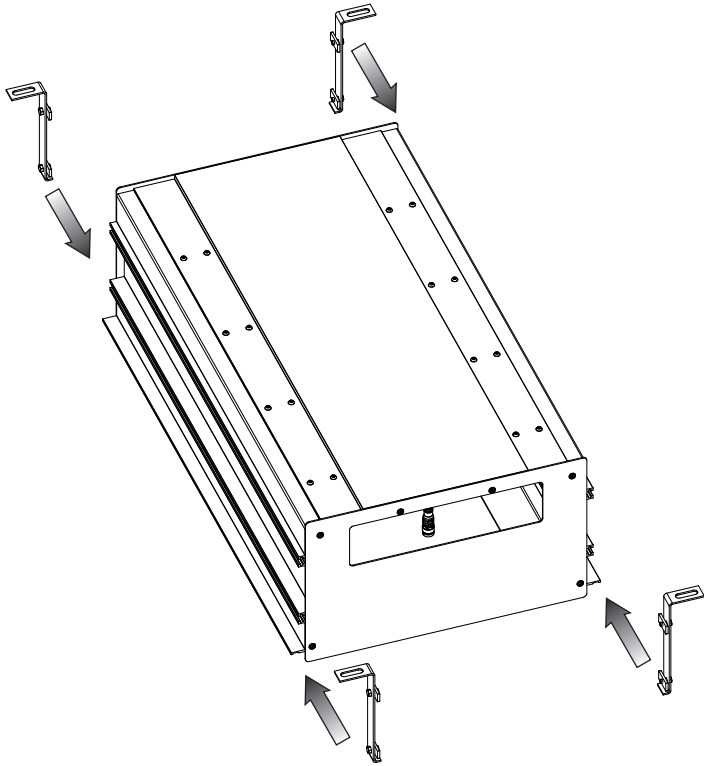

Ch. 8 mm

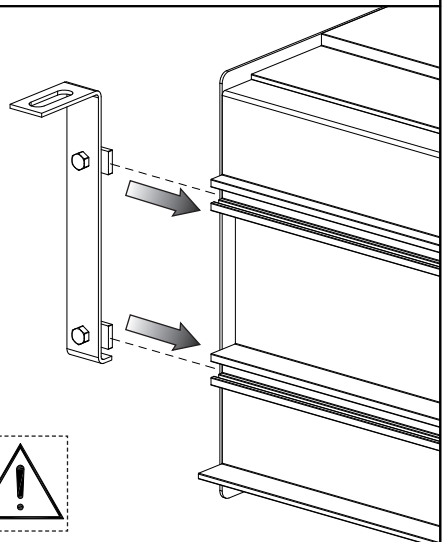



Fig. 7

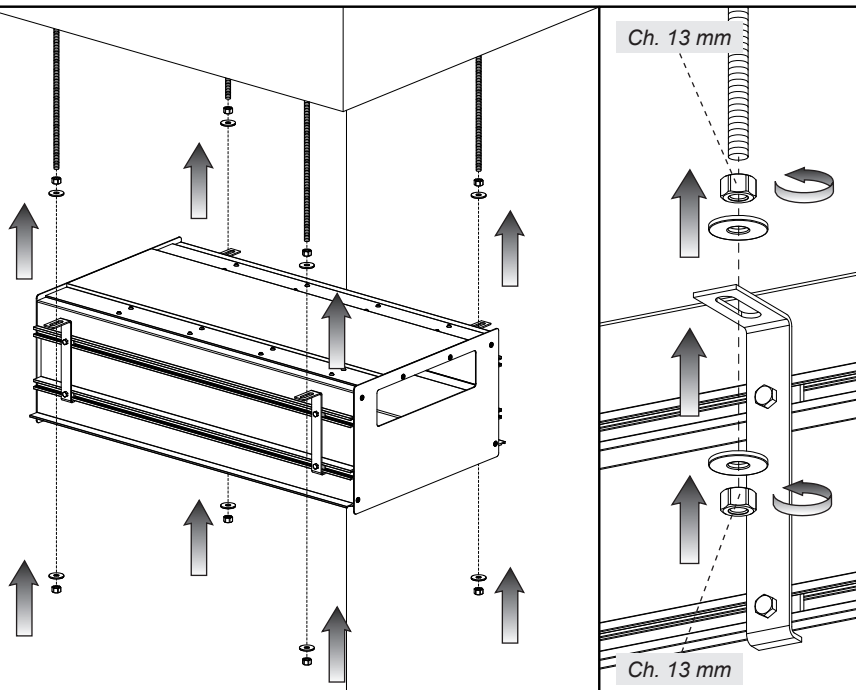
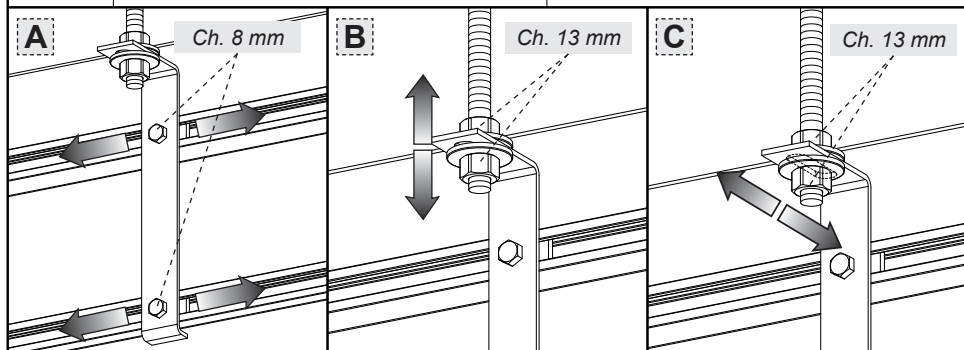
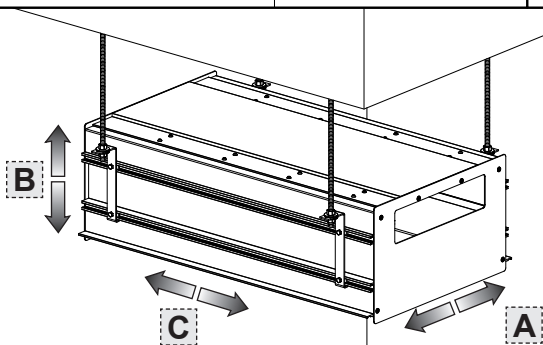
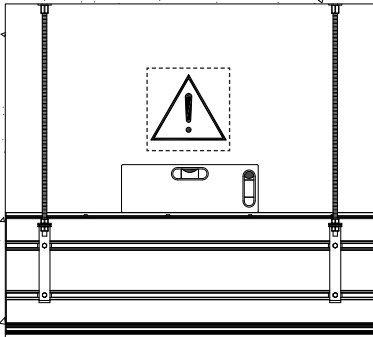

Fig. 8





**Fig. 9**



**Fig. 10**

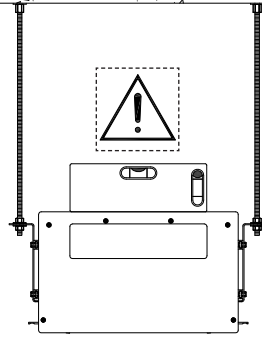
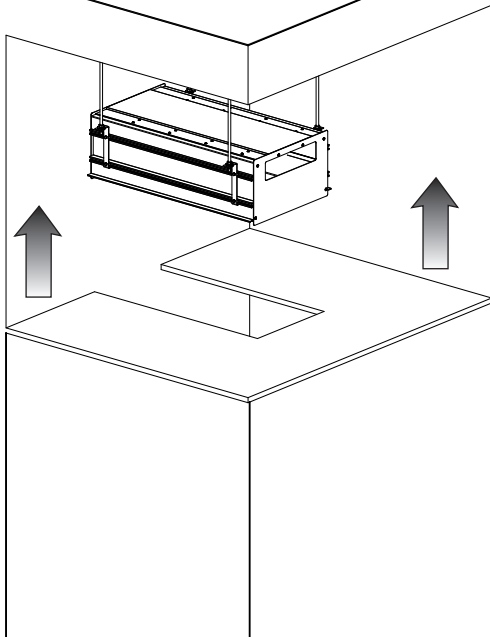
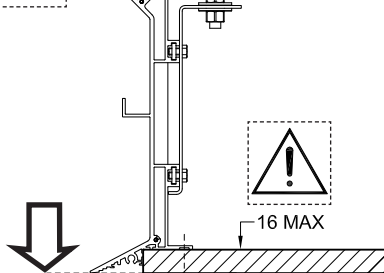



Fig. 11



Case A



Case B

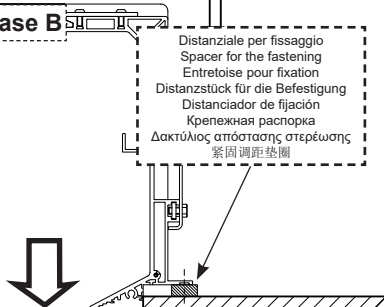

Fig. 12

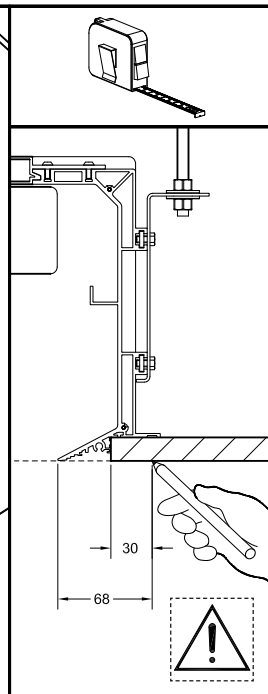
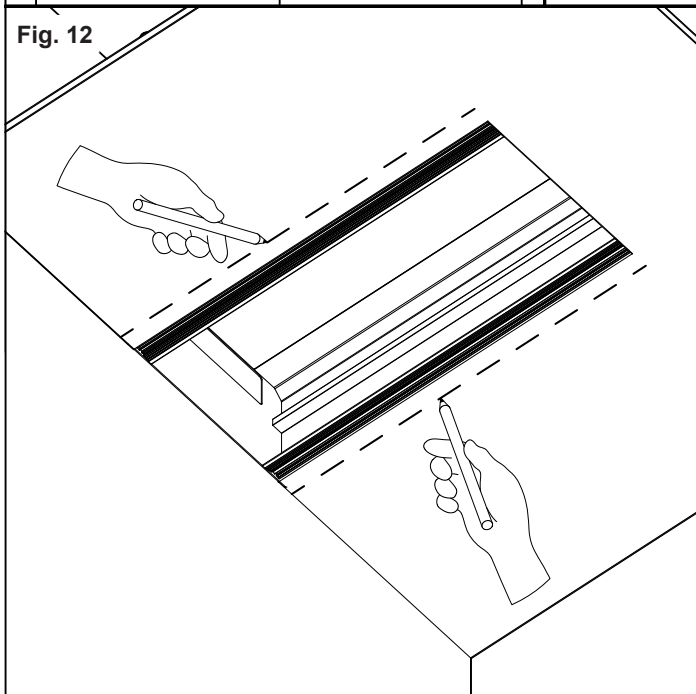



Fig. 13

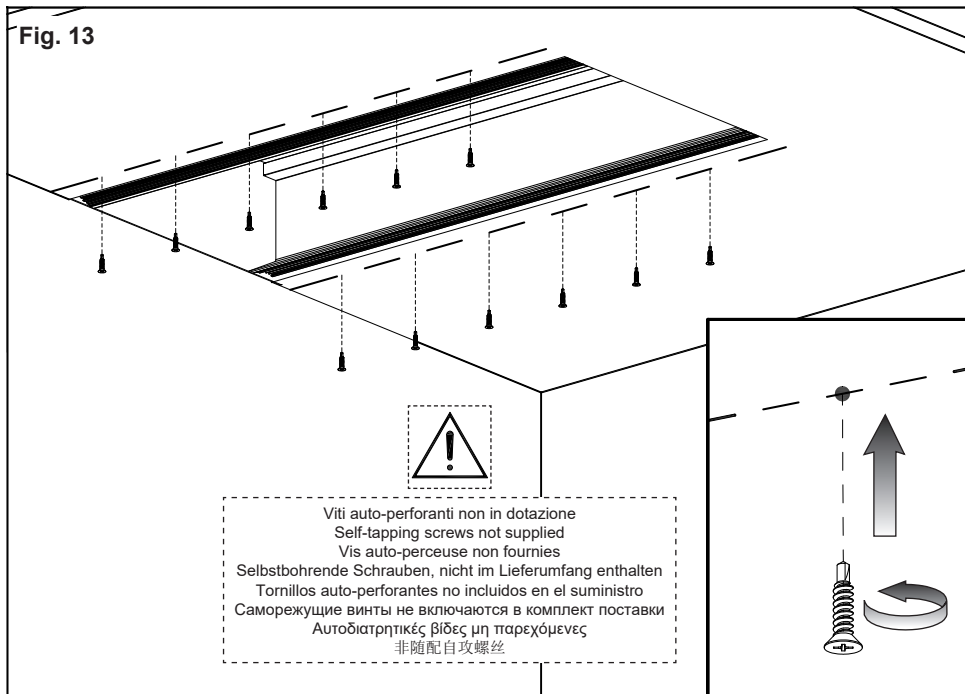

Fig. 14

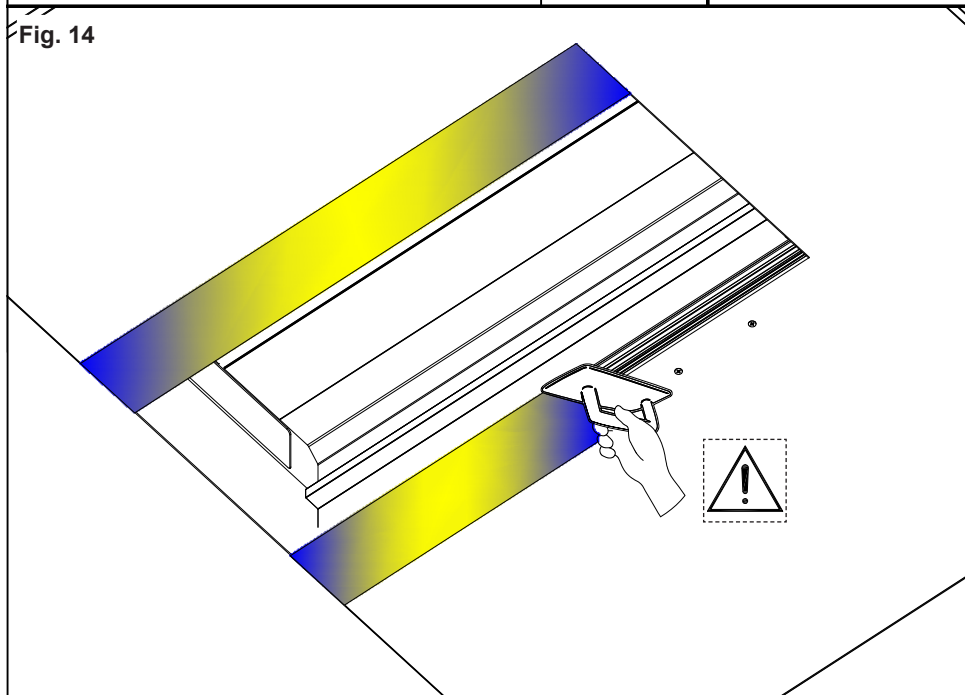



Fig. 15

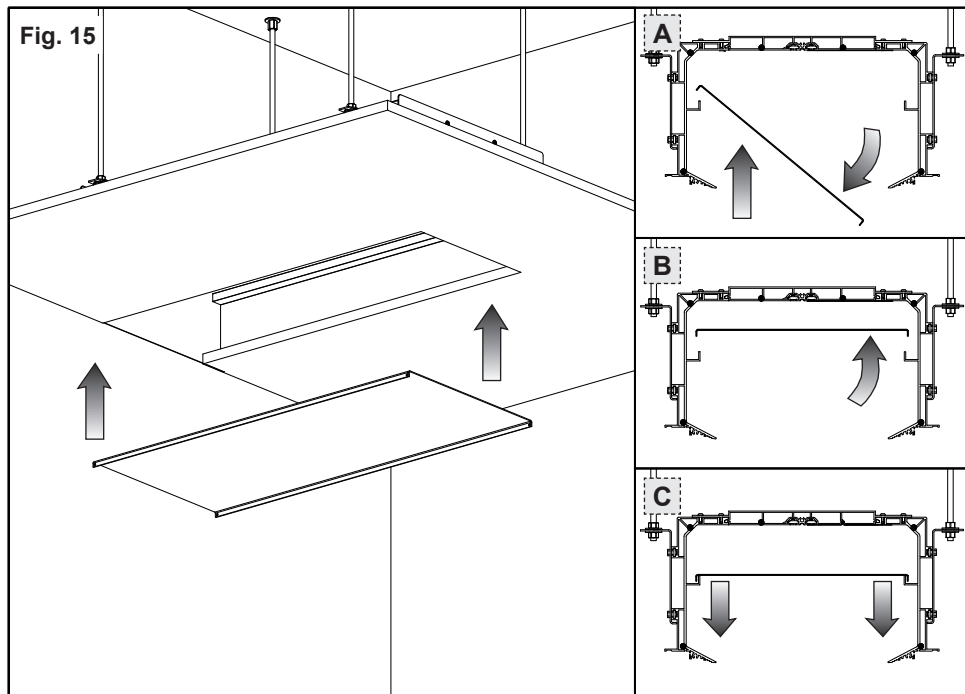



Fig. 16

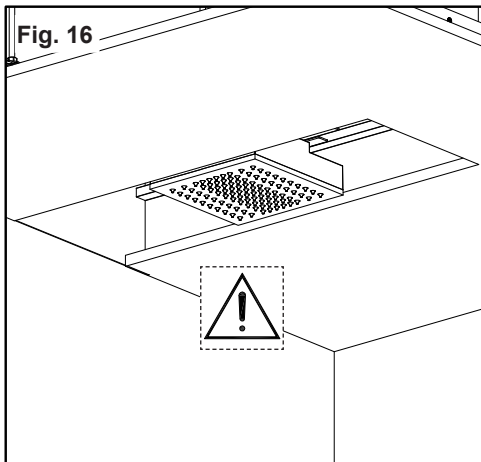

Fig. 17

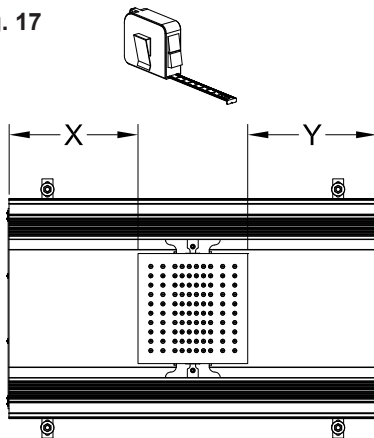

Fig. 18

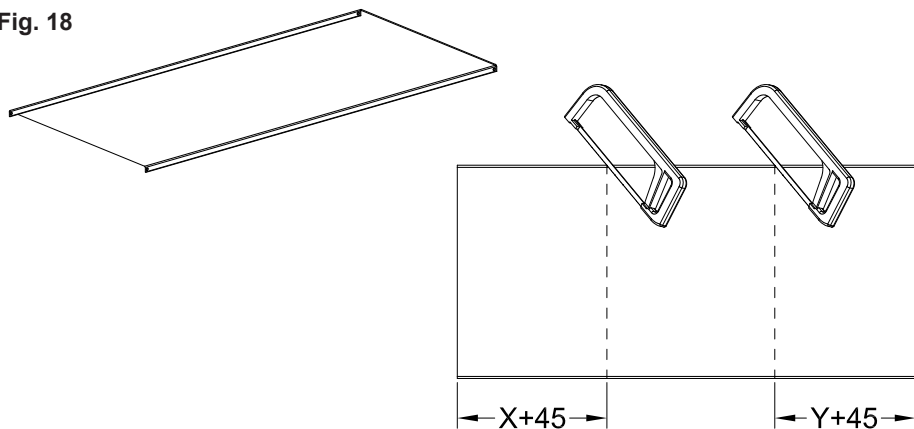

Fig. 19

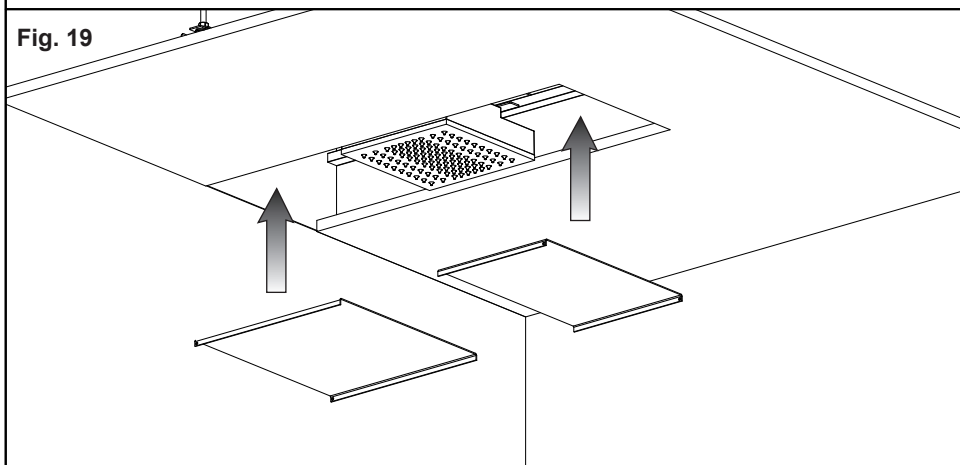





Fig. A

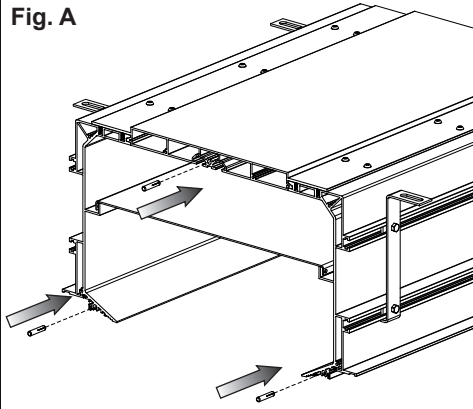

Fig. B

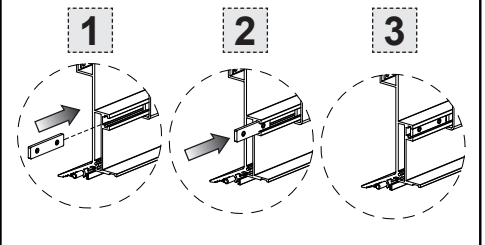
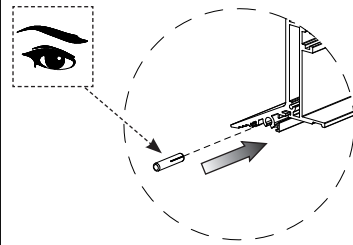
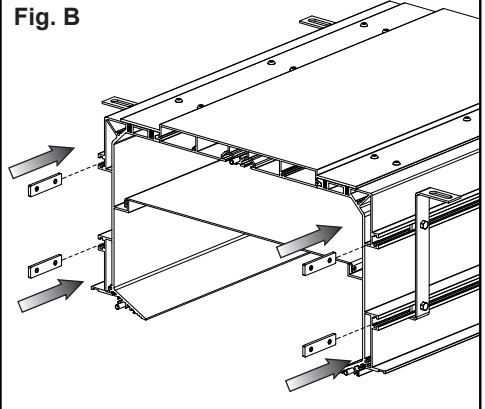

Fig. C

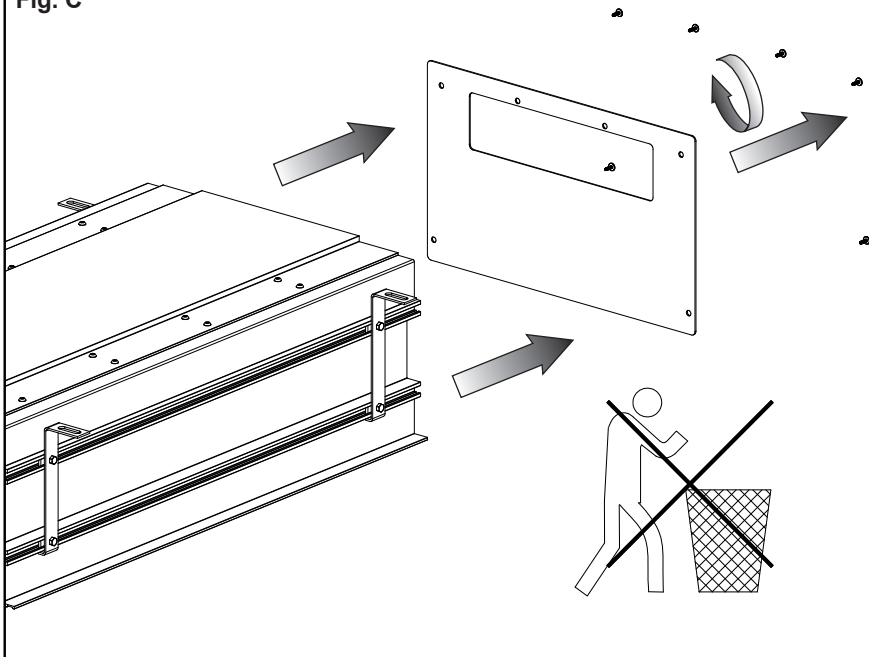



Fig. D

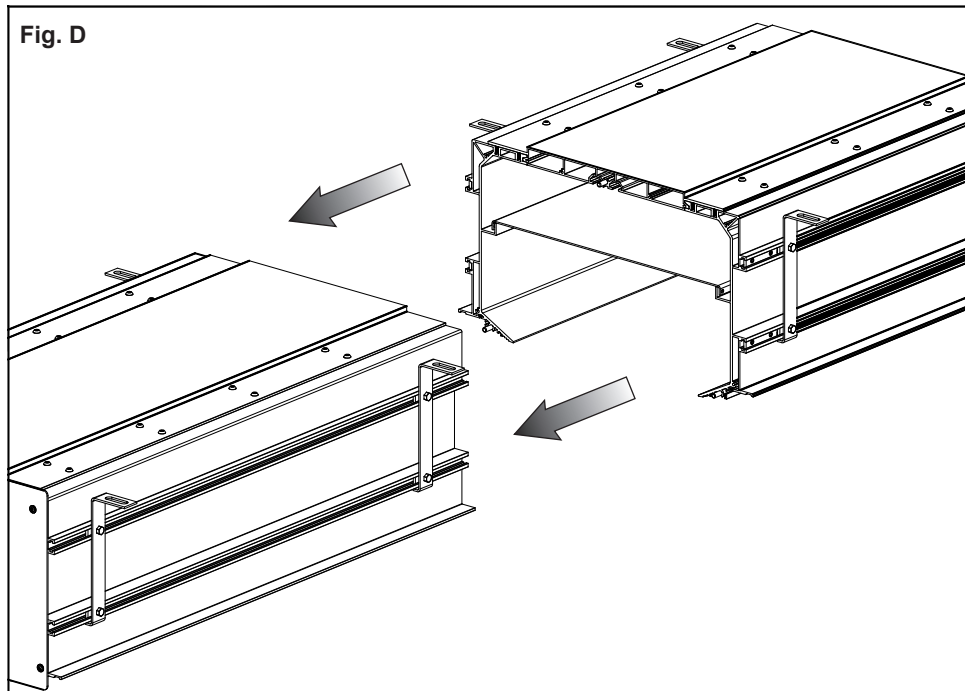

Fig. E

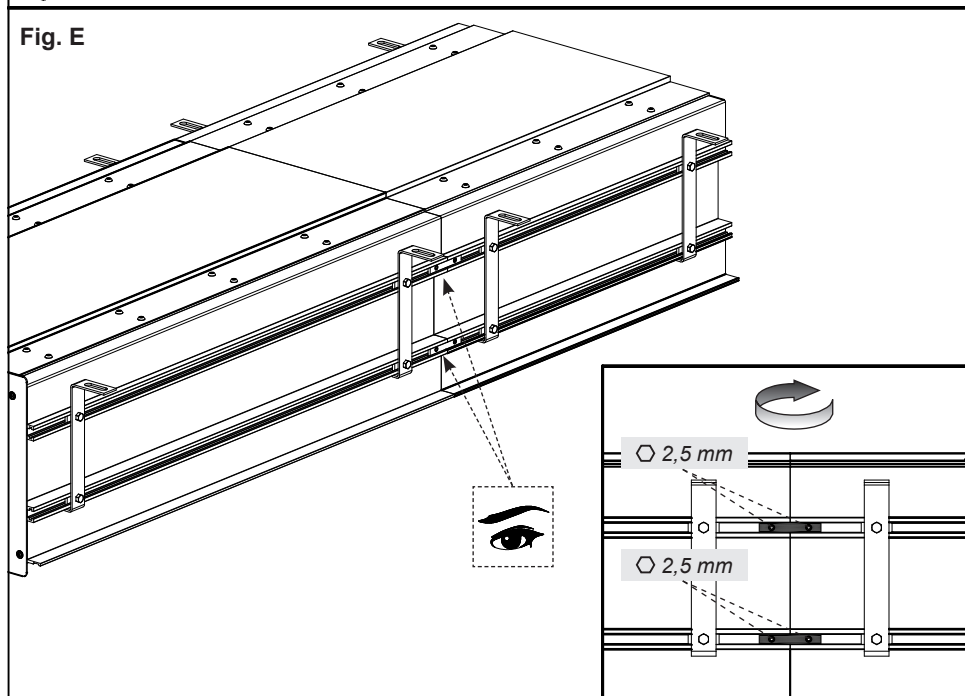
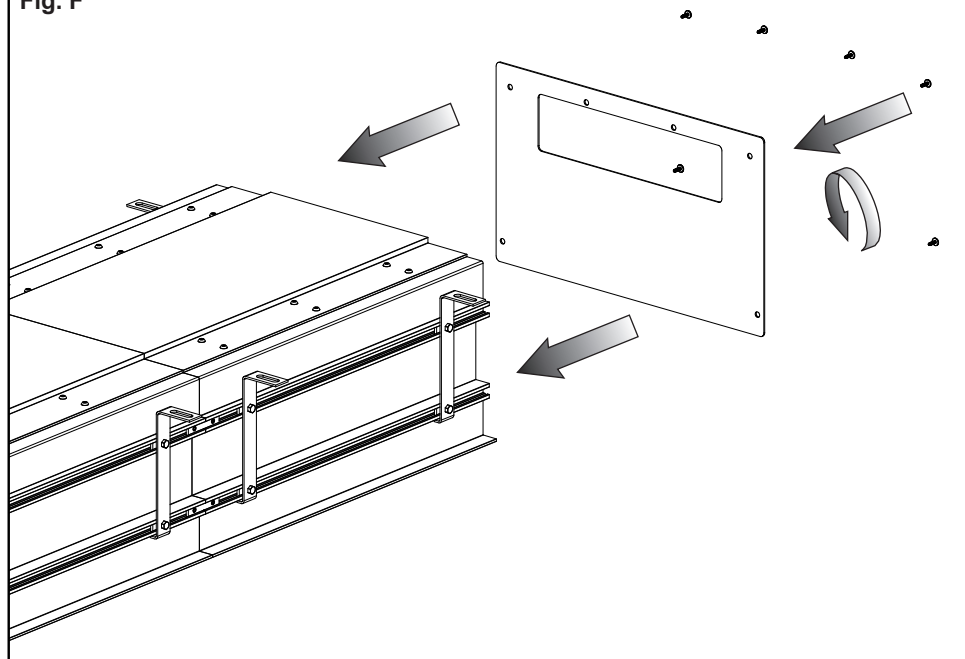

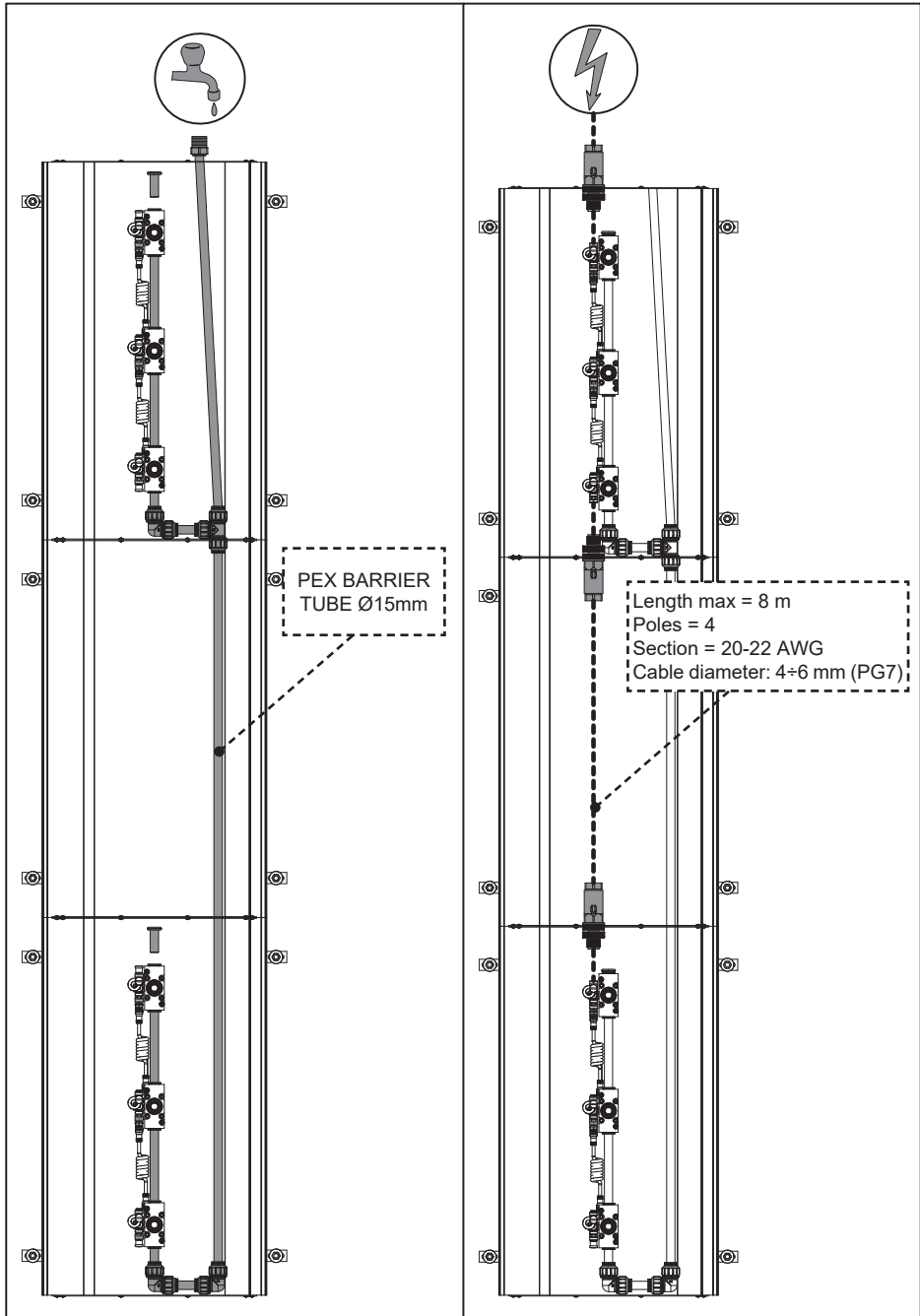

Fig. F





## CASE 1





## CASE 2

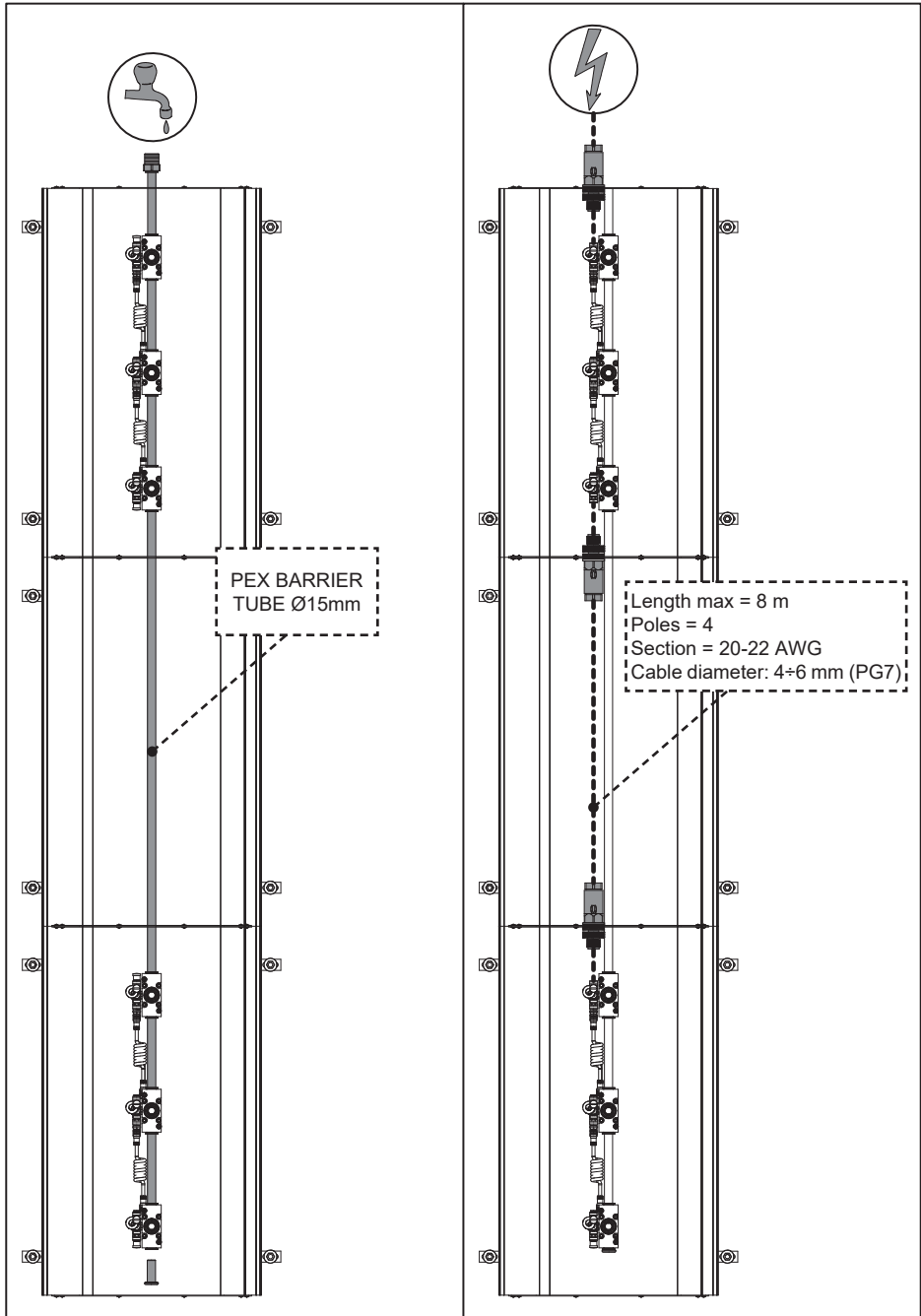



#### **MANUTENZIONE**

- Nel caso sia necessario sostituire uno o più componenti, contattare un rivenditore autorizzato o visitare il sito [WWW.GESSI.COM](http://WWW.GESSI.COM)
- Affidare la manutenzione del prodotto a personale qualificato

#### **MAINTENANCE**

- Should it be necessary to replace one or more components, contact an authorized retailer or visit [WWW.GESSI.COM](http://WWW.GESSI.COM)
- Product maintenance should be made only by qualified staff

#### **ENTRETIEN**

- S'il est nécessaire de remplacer un ou plusieurs composants, contacter un centre autorisé ou visiter le site [WWW.GESSI.COM](http://WWW.GESSI.COM)
- L'entretien du produit ne doit être effectué que par du personnel qualifié

#### **WARTUNG**

- Falls das Auswechseln von einem oder mehreren Bestandteilen erforderlich wird, kontaktieren Sie bitte einen autorisierten Fachhandel oder besuchen Sie unsere Website unter [WWW.GESSI.COM](http://WWW.GESSI.COM)
- Die Instandhaltung des Produktes sollte nur qualifiziertem Personal anvertraut werden.

#### **MANUTENCIÓN**

- En el caso de que sea necesario remplazar uno o más componentes, contacten con un revendedor autorizado o visiten el sitio [WWW.GESSI.COM](http://WWW.GESSI.COM)
- Encarguen sólo a personal calificado para el mantenimiento del producto

#### **ОБСЛУЖИВАНИЕ**

- В случае если будет необходимо заменить один или несколько компонентов, обратитесь к авторизованному дистрибьютору или посетите веб-сайт [WWW.GESSI.COM](http://WWW.GESSI.COM)
- Обслуживание изделия должен выполнить квалифицированный персонал.

#### **ΣΥΝΤΗΡΗΣΗ**

- Σε περίπτωση που είναι απαραίτητο να αντικαταστήσετε ένα ή περισσότερα εξαρτήματα, επικοινωνήστε με ένα εξουσιοδοτημένο κατάστημα πώλησης ή επισκεφθείτε τον ιστότοπο [WWW.GESSI.COM](http://WWW.GESSI.COM)
- Εμπιστευθείτε τη συντήρηση του προϊόντος σε διαπιστευμένο προσωπικό

#### **保养**

- 若需替换一个或者多个部件，请联系授权分销商或浏览[WWW.GESSI.COM](http://WWW.GESSI.COM)网站
- 请让合格人士负责产品保养工作



